

Introduction

Gas Projects India P. Ltd.'s Pump Skid are factory assembled Pumps and Motors constructed as a Pump Skid for transfer, decanting & dispensing solution. The Skid is designed and manufactured for ease of installation and operation.

Pump Skid are designed to customized transfer and dispensing requirements.

The Pump and Motor are mounted on a base frame duly aligned with all the pipe fittings and accessories.

Accessories

- Strainer
- Sight Glass
- By Pass Valve
- Non Return Valve.

Key Features of Pump Skid

- Ideal for dual hose dispensers and multiple dispensers
- ANSI or DIN flanges
- Continuous duty capability
- Self-aligning, free-floating impeller
- Heavy duty bearings
- Standard FLP motors to IS 2148
- Metric fasteners
- Ductile iron case
- Designed for 50 Hz
- Easy to install
- Factory aligned

PUMP SKID

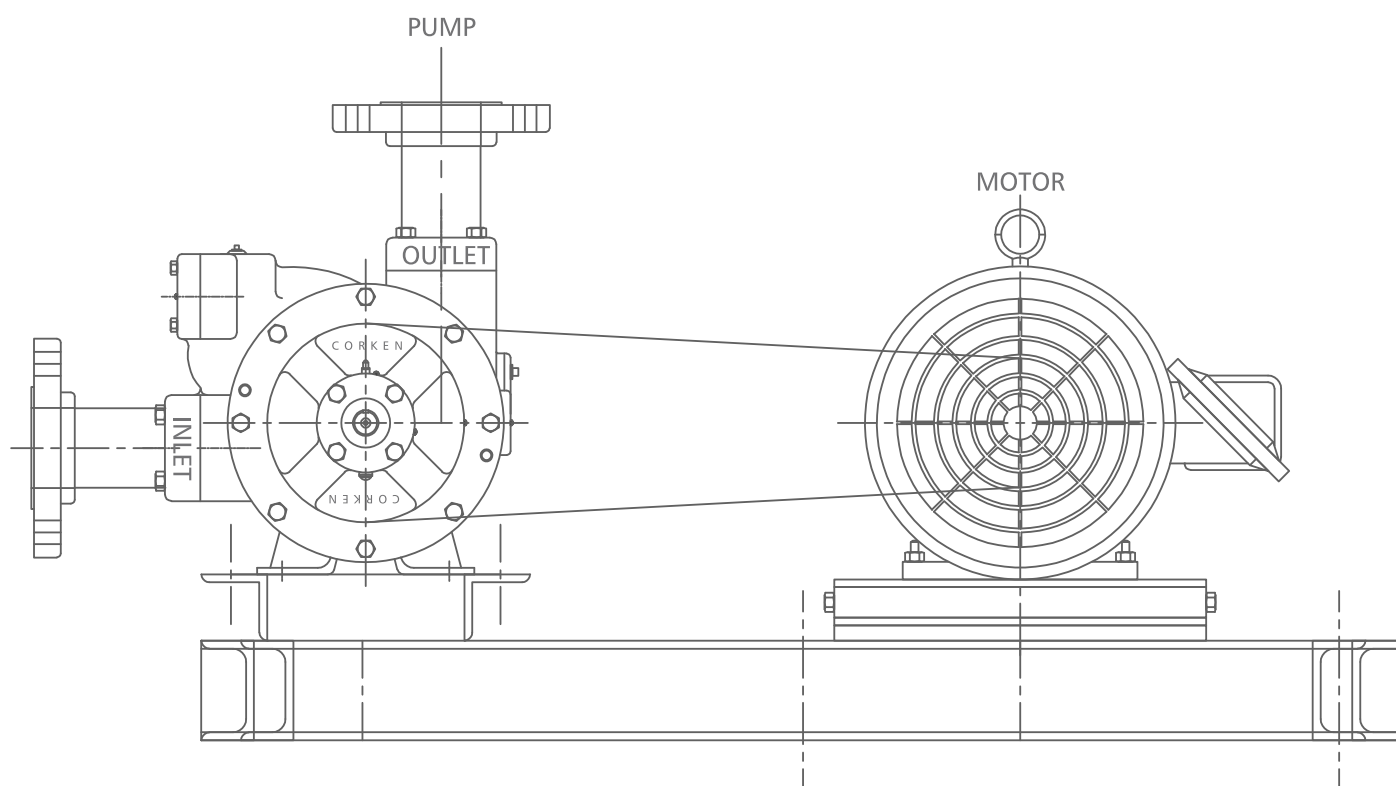

SERVICE	PUMP MODEL	MOTOR CAPACITY IN HP	FLOW RATE IN LPM	DIFFERENTIAL PRESSURE IN BAR	SHIPPING WEIGHT IN Kgs.	POWER CABLES
Transfer	Z 2000	5	200	2	110	Cu. 3 Core 2.5 mm ²
Transfer	521	7.5	250	4	125	Cu. 3 Core 2.5 mm ²
Dispensing	FF 150	7.5	100	6	125	Cu. 3 Core 2.5 mm ²
Transfer	1021	12.5	400	4	180	Cu. 3 Core 4.5 mm ²